



ULTRATON

Foshan Ultraton Engineering Machinery Co., Ltd

20m³ Semi Tanker Trailer



Ultraton 20m³ Tank Semi Trailer is a properly designed model ideal to transport fuel. It can be modified according to customer's requirement.

Overview of 20m³ Semi Tanker Trailer

- Heavy duty and extra durability designed for chassis frame and main beam.
- Thickness of top plate, side plate and bottom plate of tank barrel could be customized
- Steel material we use on barrel, bulkhead and baffle is carbon steel Q235B
- Welded by automatic submerged-arc process and skilled technicians. Complete chassis shot blasting to clean rust.
- Optional for one or more compartments
- All tank fittings are strictly selected domestic famous brand for filling and unloading system and safety protection system
- Superior quality and famous brand we use on specific different trailer parts. Details are outlined as below





ULTRATON

Foshan Ultraton Engineering Machinery Co., Ltd



Advantage of 20m³ Semi Tanker Trailer

1. Different shape and material of tank is optional for solution
2. Shipped both by container, or RORO, bulk shipment.
3. Nice and attractive appearance with our good workmanship
4. Fast response and flexible service from our professional team
5. Distinct location to get full range support on delivery and manufacturing
6. The long term tenet of Ultraton as one of the standout [semi trailer manufacturers](http://www.ultrontrailer.com) to be your reliable partner bringing you Greater value makes you worry free on after sales service

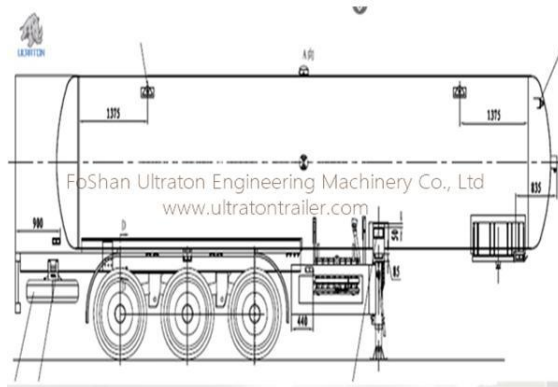

Technical Parameter	20m ³ Tanker Semi Trailer
TANK BARREL	
Tank Profile	Elliptical, Straight, Maximum profile design that maximizes volumetric capacity whilst achieving a low centre of gravity.
Design Code/Testing	According to china standard, refer to ADR Standard.
Capacity	Hydrostatic test to 5 psi (35 Kpa) on each compartment 20000L plus maximum 5% Ullage.
Main Beam	Carbon steel Extrusion, full-length main frame.
Roll Over Coaming	Carbon steel Extrusion in inverted "U" section, for roll over protection. At least 30mm above any fittings on the top of the barrel, 3/8" degassing plug at the front-top & rear-bottom.
FITTINGS AND PIPING	
Manhole Cover	Domestic manhole cover, with relief valve (top inlet for oil), Pressure Vacuum Vent, overflow hole and vapour transfer vent hole (*5)



ULTRATON

Foshan Ultraton Engineering Machinery Co., Ltd

Pressure Vacuum Vent	Domestic, roll-over type incorporates with manhole cover (*5)
Vapour Vent	Domestic, sequential pneumatic control air vent (*5)
Vapour Recovery Hose	3" hose, connected with vapour vent to the left side coaming rail, Stainless steel hose clips as need.
Vapour Recovery Piping	4" Carbon steel pipe from rear right side roll over coaming to rear of the barrel, outside of the barrel, connected with vapour recovery adaptor.
Vapour Recovery Adaptor	Domestic with pneumatic vapour interlock valve and dust cap, install at rear right side of the barrel. (*1)
Vapour Dump Vent	Domestic, air operated, dump vent close when the vapour adaptor is activated, installed at the rear right inner side of roll over coaming, vented to atmosphere. (*1)
Emergency Valve	pneumatic controlled emergency valve at all compartments, flange coupling to discharge pipe (*5)
Discharge Piping	4" Carbon steel discharge pipe to the right side of trailer with minimum number of bends. Piping to be hydro-statically tested. The piping slope toward front at angle of 2-3 degrees.
Loading & Discharge Valve	DN 80 du type FIDLOCK adaptor c/w flange type sight glass & dust cap on the right side at centre of tanker. The offset distance from centre to centre of API is 300mm. (*5)
Overfill Prevention	Civacon 5 wire optic probe installed to manhole cover, 1 piece Civacon 10 pin, 3J slot plug socket installed above the discharge control cabinet. (*5) Probe need to be set at minimum 25mm above top full ullage marker in each compartment. RUNNING GEAR
Landing Gear	Standard 28Ton , FUWA Brand
Axle	Standard FUWA Brand / ULTRATON Brand Optional : BPW Brand or HuaJing Brand
Suspension	Mechanical Suspension/Air Suspension, Standard FUWA Brand/ULTRATON Brand Optional : BPW Brand or HuaJing Brand
Tire	12.00R22.5 Tubeless
Rim	9.0*22.5
Shot Blasting & Painting	Shot Blasting and Sanding Treatment . Two Coat Of Anti Corrosion Primer and Two Coat Of Finish Painting
Tool Box	1 Standard (The Tool Box Size Can Be Tailored To Suit Your Needs)
We Can Build The Trailer According To Customer's Design And Requirement.	

Application of 20m³ Semi Tanker Trailer

Ultraton's [20m³ Tank Semi Trailer](#) could be used to transport different oils dispensed separately or in separate positions.



ULRATON

Foshan Ultraton Engineering Machinery Co., Ltd

