



**ULTRATON**

Foshan Ultron Engineering Machinery Co., Ltd

### 3 Axles 20ft Skeletal Container Transport Semi Truck Trailer



Ultron's 3 Axles 20ft Skeleton Semi Shipping Container Trailer, or 20ft Skeletal Trailer for short, is equipped with 3 pieces of semi-trailer axles to ensure loading capacity and commonly used as a basic design. Extendable Chassis and Multipurpose Container Trailer can be modified according to the customer's requirement. We offer high-quality tri axle skeletal trailer for sale.

#### Overview of 3 Axles 20ft Skeletal Container Transport Semi Truck Trailer

- Scientific design with advanced computer-aided design software, finite element analysis of the frame according to vehicle load quality requirements
- Flange and web width & thickness could be customized
- 16 manganese high strength steel is used in heavy duty and extra durability designed for main I beam.
- Specific auto hydraulic I beam straightening machine for more accuracy
- Welded by automatic submerged-arc process. Complete chassis shot blasting to clean rust.
- Superior quality and famous brand we use on specific different trailer parts. Details are outlined as below.



#### Advantage of 3 Axles 20ft Skeletal Container Transport Semi Truck Trailer

1. Mature technology, could be produced in large quantity at competitive cost
2. Lighter weight with high strength to transport container

[www.ultrontrailer.com](http://www.ultrontrailer.com)

[inquiry@ultrontrailer.com](mailto:inquiry@ultrontrailer.com)

**ULTRATON**

Foshan Ultraton Engineering Machinery Co., Ltd

3. Shipped both by container, or RORO, bulk shipment
4. Nice and attractive appearance with our good workmanship
5. Fast response and flexible service from our professional team
6. Distinct location to get full range support on delivery and manufacturing
7. The long term tenet of Ultraton as one of the standout [semi trailer manufacturers](http://www.ultratontrailer.com) to be your reliable partner bringing you Greater value makes you worry free on after sales service

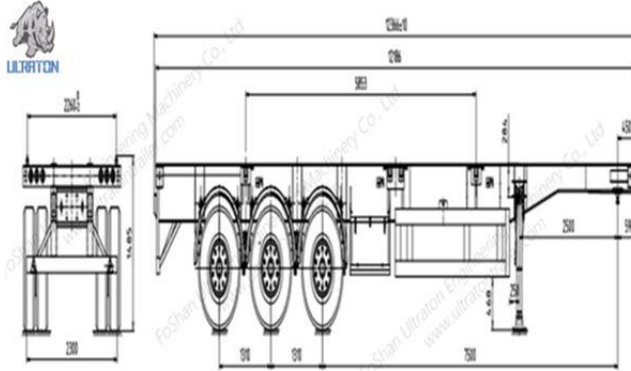

Technical Parameter	3 Axles 20ft Skeleton Container Transport Semi Truck Trailer
Tare Weight(KG)	5000KG
Loading Capacity(KG)	40000KG
Dimension(mm)	8500*2500*1500
Main Beam	The height of the beam is 500 mm, upper Flange is14mm, Lower Flange is 14mm,Web is 8mm.
Kingpin	2"/ 3.5",Welded/Bolt-In
Landing Gear	Standard 28Ton , FUWA Brand
Axle	Standard FUWA Brand / ULTRATON Brand Optional : BPW Brand or HuaJing Brand
Suspension	Mechanical Suspension/Air Suspension,Standard FUWA Brand/ULTRATON Brand Optional : BPW Brand or HuaJing Brand
Leaf Spring	Standard FUWA Brand/ULTRATON Brand 90mm*16*7 or 90*16*8
Brake system	Dual Air Brake (Drum) System, With Inter-Locking Device.WABCO Relay Emergency Valve,OPTIONS: ABS.
Electrical System	24 Volt LED Electrical System In Accordance To The Standard, With 7-Core Adaptor For Tractor.
Tire	12.00R22.5 Tubeless,12 Units
Rim	9.0*22.5,12 Units
Shot Blasting & Painting	Shot Blasting and Sanding Treatment . Two Coat Of Anti Corrosion Primer and Two Coat Of Finish Painting
Mud Guard	Fabricated Mud Guard 6 nos
Tool Box	1 Standard (The Tool Box Size Can Be Tailored To Suit Your Needs)



**ULTRATON**

Foshan Ultraton Engineering Machinery Co., Ltd

Container Locks	4/8/12 Screw type
Spare Tire Carrier	Equipped one sets per chassis without spare tire.
We Can Build The Trailer According To Customer's Design And Requirement.	

### Application of 3 Axles 20ft Skeletal Container Transport Semi Truck Trailer

Ultraton's 20ft [tri axle skeletal trailer](#) could be used to transport standard sizes of container in ports or from site to site on road. Suitable for logistic company, terminal ports, shipping lines, forwarders, truck manufacturer

