



ULTRATON

Foshan Ultraton Engineering Machinery Co., Ltd

30T Terminal Port Container Truck Semi Trailer



Ultron's 30T enclosed cargo Container Semi Trailer is an ideal and practical way to handle containers by Low-speed tractors in specific areas such as terminals or container diversion centers efficiently. It can be modified according to customer's requirement.

Overview of 30T Terminal Port Container Truck Semi Trailer

- Heavy duty and extra durability designed for main I beam
- Flange and web width & thickness could be customized
- Guide block, bottom block and indicated bar is appropriately welded to fix containers firm and fast
- Steel material we use is high strength low alloy steel Q345
- Welded by automatic submerged-arc process. Complete chassis shot blasting to clean rust
- Superior quality and famous brand we use on specific different trailer parts. Details are outlined as below



Advantage of 30T Terminal Port Container Truck Semi Trailer

1. Mature technology, could be produced in large quantity at competitive cost
2. Lighter weight with high strength to transport container

www.ultrontrailer.com

inquiry@ultrontrailer.com



ULRATON

Foshan Ultraton Engineering Machinery Co., Ltd

3. Shipped both by container, or RORO, bulk shipment
4. Nice and attractive appearance with our good workmanship
5. Fast response and flexible service from our professional team
6. Distinct location to get full range support on delivery and manufacturing
7. The long term tenet of Ultraton as one of the standout [semi trailer manufacturers](#) to be your reliable partner bringing you Greater value makes you worry free on after sales service

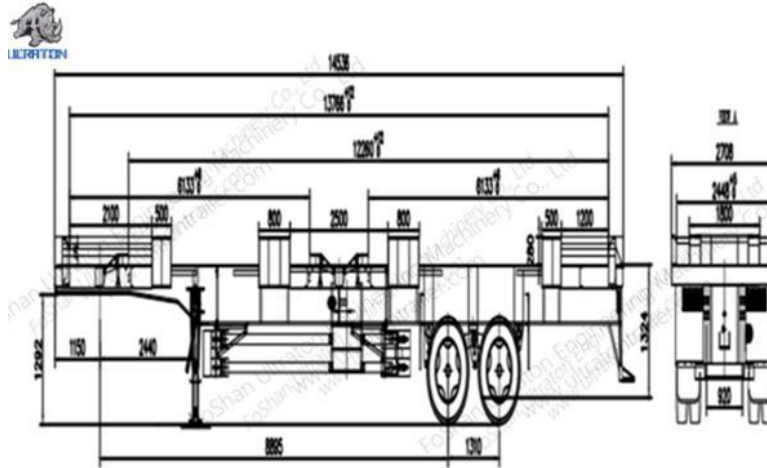

Technical Parameter	30T Terminal Port Container Truck Semi Trailer
Tare Weight(KG)	5700KG
Loading Capacity(KG)	30000KG
Dimension(mm)	13950*2500*2760
Main Beam	The height of the beam is 500 mm, upper Flange is 14mm, Lower Flange is 14mm, Web is 8mm.
Kingpin	2" / 3.5", Welded/Bolt-In
Landing Gear	Standard 28Ton , FUWA Brand
Axle	Standard FUWA Brand / ULTRATON Brand Optional : BPW Brand or HuaJing Brand
Suspension	Mechanical Suspension/Air Suspension, Standard FUWA Brand/ULTRATON Brand Optional : BPW Brand or HuaJing Brand
Leaf Spring	Standard FUWA Brand/ULTRATON Brand 90mm*16*7 or 90*16*8
Brake system	Dual Air Brake (Drum) System, With Inter-Locking Device. WABCO Relay Emergency Valve, OPTIONS: ABS.
Electrical System	24 Volt LED Electrical System In Accordance To The Standard, With 7-Core Adaptor For Tractor.
Tire	12.00R22.5 Tubeless, 8 Units
Rim	9.0*22.5, 8 Units



ULTRATON

Foshan Ultraton Engineering Machinery Co., Ltd

Shot Blasting & Painting	Shot Blasting and Sanding Treatment . Two Coat Of Anti Corrosion Primer and Two Coat Of Finish Painting
Mud Guard	Fabricated Mud Guard 4 nos
Tool Box	1 Standard (The Tool Box Size Can Be Tailored To Suit Your Needs)
Spare Tire Carrier	Equipped one sets per chassis without spare tire.
Flapper	According To Customer's Requirement
Guide Block	According To Customer's Requirement
We Can Build The Trailer According To Customer's Design And Requirement.	

Application of 30T Terminal Port Container Truck Semi Trailer

Ultraton's 30T [enclosed semi trailer](#) could be used to transport standard sizes of container in ports or from site to site on road. Suitable for logistic company, terminal ports, shipping lines, forwarders, truck manufacturer

