

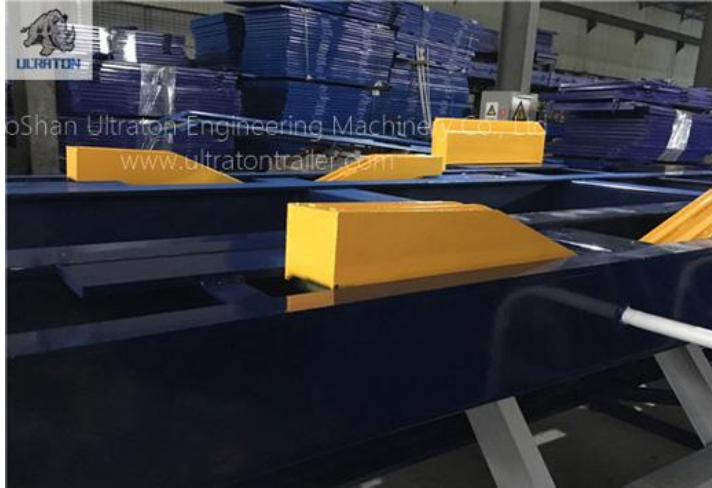

**ULTRATON**

Foshan Ultraton Engineering Machinery Co., Ltd

## 40T Terminal Port Container Truck Semi Trailer



Ultraton's 40T Container Terminal Semi Trailer is an ideal and practical way to handle containers by Low-speed tractors in specific areas such as terminals or container diversion centers efficiently. It can be modified according to customer's requirement.

### Overview of 40T Terminal Port Container Truck Semi Trailer

- Space frame welded structure, which is formed by welding two I-shaped longitudinal beams and a plurality of beams (C-shaped channel steel).
- Steel material we choose to use is high strength steel Q345.
- Whole body is welded by advanced automatic submerged-arc process and skilled technicians. Complete chassis shot blasting to clean rust and remove welding stress.
- Superior quality and famous brand we use on specific different trailer parts. Details are outlined as below.



### Advantage of 40T Terminal Port Container Truck Semi Trailer

1. Mature technology, could be produced in large quantity at competitive cost
2. Lighter weight with high strength to transport container
3. Shipped both by container, or RORO, bulk shipment.

[www.ultrontrailer.com](http://www.ultrontrailer.com)

[inquiry@ultrontrailer.com](mailto:inquiry@ultrontrailer.com)



**ULTRATON**

Foshan Ultraton Engineering Machinery Co., Ltd

4. Nice and attractive appearance with our good workmanship
5. Fast response and flexible service from our professional team
6. Distinct location to get full range support on delivery and manufacturing
7. The long term tenet of Ultraton as one of the standout [semi trailer manufacturers](#) to be your reliable partner bringing you Greater value makes you worry free on after sales service

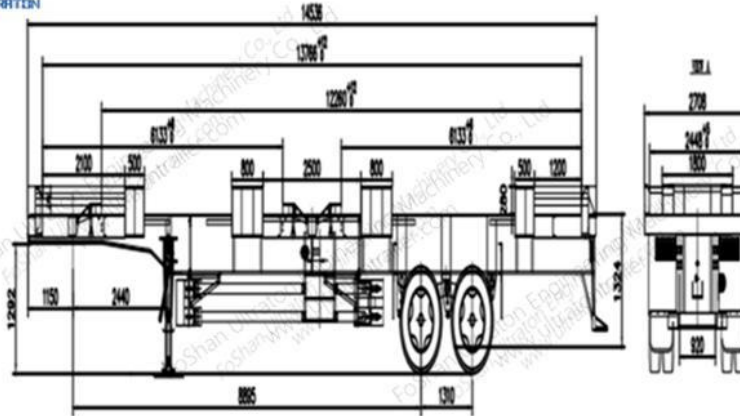

Technical Parameter	40T Terminal Port Container Truck Semi Trailer
Tare Weight(KG)	5700KG
Loading Capacity(KG)	40000KG
Dimension(mm)	13950*2500*2760
Main Beam	The height of the beam is 500 mm, upper Flange is 14mm, Lower Flange is 14mm, Web is 8mm.
Kingpin	2"/ 3.5", Welded/Bolt-In
Landing Gear	Standard 28Ton , FUWA Brand
Axle	Standard FUWA Brand / ULTRATON Brand Optional : BPW Brand or HuaJing Brand
Suspension	Mechanical Suspension/Air Suspension, Standard FUWA Brand/ULTRATON Brand Optional : BPW Brand or HuaJing Brand
Leaf Spring	Standard FUWA Brand/ULTRATON Brand 90mm*16*7 or 90*16*8
Brake system	Dual Air Brake (Drum) System, With Inter-Locking Device. WABCO Relay Emergency Valve, OPTIONS: ABS.
Electrical System	24 Volt LED Electrical System In Accordance To The Standard, With 7-Core Adaptor For Tractor.
Tire	12.00R22.5 Tubeless, 8 Units
Rim	9.0*22.5, 8 Units
Shot Blasting & Painting	Shot Blasting and Sanding Treatment . Two Coat Of Anti Corrosion Primer and
Mud Guard	Two Coat Of Finish Painting Fabricated Mud Guard 4 nos



**ULTRATON**

Foshan Ultraton Engineering Machinery Co., Ltd

Tool Box	1 Standard (The Tool Box Size Can Be Tailored To Suit Your Needs)
Spare Tire Carrier	Equipped one sets per chassis without spare tire.
Flapper	According To Customer's Requirement
Guide Block	According To Customer's Requirement
We Can Build The Trailer According To Customer's Design And Requirement.	

### Application of 40T Terminal Port Container Truck Semi Trailer

Ultraton's [40T Container Terminal Semi Trailer](#) is one kind of modified Skeleton Semi Trailer which is specifically worked in terminal port for load and lifting containers precisely and quickly. Especially suitable for terminal ports, shipping lines.

